



DESIGN AND HARDWARE IMPLEMENTATION OF AUTOMATIC TRAFFIC CONTROL FOR AMBULANCES TO SAVE HUMAN LIVES

A. Kalaimurugan^a, R. Praveen Kumar^b, M.C.John Wiselin^c

Department of EEE, Agni College of Technology,

^a e-mail: kalaimurugan.eee@act.edu.in, ^b e-mail: praveenkumar.eee@act.edu.in

Abstract

This paper provides solution to the problems faced by the ambulance drivers during emergency conditions. This is done in order to save the life of the person inside the ambulance who needs immediate medical treatment by reaching the hospital. This paper includes the use of Received Signal Strength Indication (RSSI) technology to detect the presence of the ambulance under emergency condition and changing the lights of the traffic signal depending on the signal strength. When the presence of the ambulance under emergency condition is detected, the traffic signal is changed so that the ambulance can cross the traffic signal and reach the hospital as soon as possible. When the ambulance crosses the traffic signal, the regular sequence of flow of the traffic signal is restored.

Keywords: RSSI Technology, Traffic lights, hospital

I INTRODUCTION

Traffic signal is a signaling device positioned at a road intersection, pedestrian crossing, or similar locations in order to indicate when it is safe to drive, ride, or walk using a universal color code. In common, the traffic lights for vehicles commonly have three main lights, a red light that means stop, a green light that mean go and yellow that means ready to stop. The traffic lights have given many benefits to all road users. Besides reducing the number of accidents, it made the traffic flow smoothly and possibly could save people time.

A. *Background History*

The world's first traffic light was installed in London in December 1868. It was a manually operated gas-lit signal, which exploded less than a month after it was implemented. EarnstSirrine from Chicago invented the first automatic traffic control system in 1910. It indicated signs such as stop, wait and go, but it did not show any color.

In 1920, the world's first 4-way three color traffic light was invented on the corner of Woodward and Michigan Avenues in Detroit. Within a year, fifteen automatic traffic lights were installed in Detroit.

B. *Problem Statements*

The current system of traffic light has been to provide a fixed traffic control plan, whose settings are based on prior traffic counts but may be manually changed. It is the most common form of signal control

and result in inappropriate behavior in traffic which differs from that which the plan was based, such as the use of unnecessary phases when the traffic is light.

C. The current system of traffic light

The traffic jam is the common problem in most of the cities in the world. One of the main causes of this problem is accident. To find the way to maximize the traffic flow smoothly can reduce the numbers of the accident and can reduce the time people spend on the road. The government has carried out a few rules to overcome this problem. The traffic lights have been made at the location that high risk in accident. However, increasing the number of traffic lights has contributed to some problems:

(a) Traffic signals cause heavy traffic jams

Increasing the number of vehicles on the road due to traffic signals has caused heavy traffic jams. This happens usually at the main junctions, commonly at the morning, before office hours and at the evening, after the office hours. The main effect of this matter is increasingly wasting time of the people at the road.

(b) No traffic, but the road user still need to wait

The traffic lights have contributed to more wasting time of the people at road. At a certain junction, sometime there would be no traffic. But because the traffic light is still red, the road users should wait until the light turns to green. If they cross the signal during red light, unfortunately they should pay the fine of about Rs.300 because of the traffic rules.

(c) Emergency car stuck in traffic jam

Our paper is mainly about this particular problem. Usually, during traffic jam, the emergency vehicle, such as ambulance, fire-brigade and police will be stuck especially at the traffic light junction. This is because the road users wait for the traffic light to turn to green. As mentioned in [1], this is a very critical problem because the emergency case can become complicated, especially when life is involved.

II PROPOSED METHODOLOGY

The proposed work in [9] describes the automatic traffic control using RFID and cloud. The proposed work in [17] describes the methodology using light based communication technology. The proposed system in [2] describes the method in which the ambulances are given the best route to reach the hospital. The RSSI working principles were obtained from various site references from [7], [8] and [10].

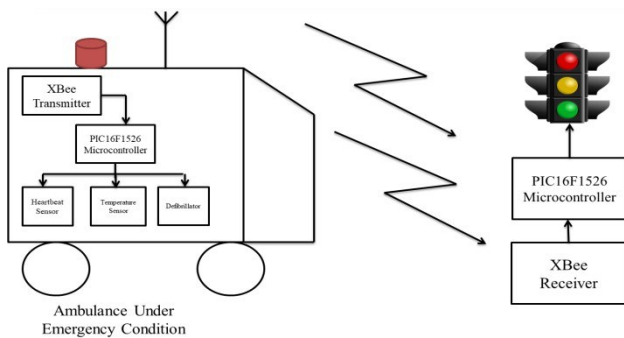

Fig. 1. Block Diagram of the Proposed System

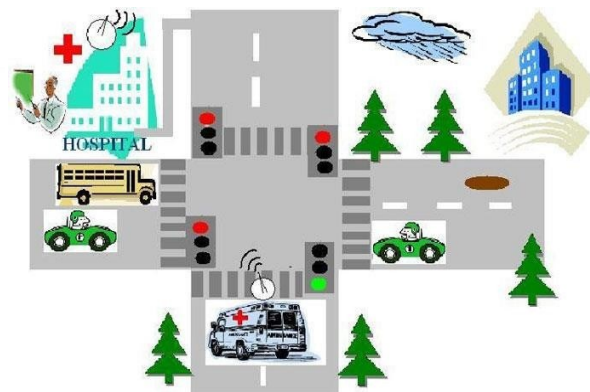

Fig. 2. Schematic Illustrating the Proposed System

The figure1 shows the block diagram of our proposed system. In our proposed system, the XBee module is provided with RSSI (Received Signal Strength Indication) in order to detect the ambulance under emergency condition based on the received signal strength. The XBee transmitter is fitted in the ambulance and is activated only when the ambulance is under emergency condition. The XBee receiver is fitted in the traffic signals. The microcontroller controls the flow of the traffic signal lights. The ambulance subsequently sends the data of the patient like blood pressure level, heart beat rate, glucose level etc.

When the ambulance under emergency condition reaches within the range of the signal strength, the traffic lights of that particular lane automatically changes to green (if red) by the microcontroller, and the traffic lights of other lane(s) change to red. Due to this process, the vehicles blocking the way of the ambulance will move so that the ambulance also moves. Once the ambulance crosses the traffic signal, the traffic light changes back to red and the normal sequence of operation continues.

III CIRCUIT DIAGRAM

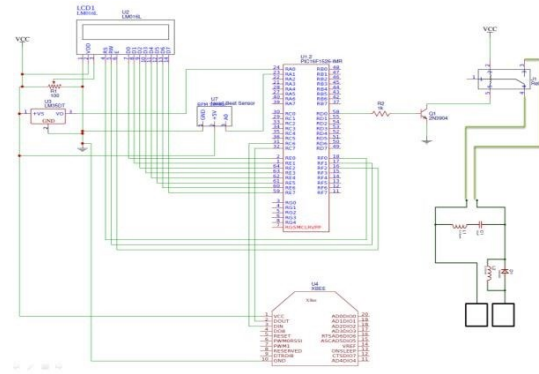
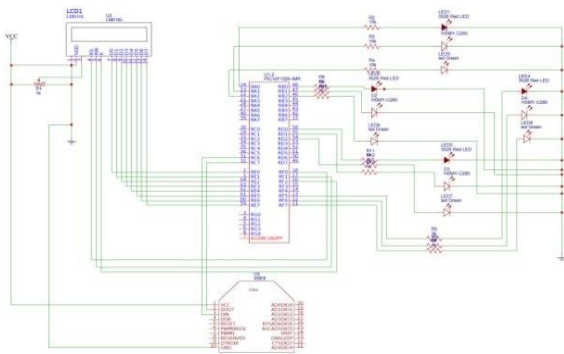

Fig. 3. Circuit Diagram for Transmitter

Fig. 4. Circuit Diagram for Receiver

The figure 3 shows the circuit diagram for transmitter and the figure 4 shows the circuit diagram for receiver. Here a PIC microcontroller is used for both the transmitter and the receiver each. For transmitter, and for the receiver each, we have used the PIC16F1526 microcontroller. These circuit diagrams were designed using the Easy EDA software. The main advantage of PIC16F1526 over PIC16F877A is that it is an advanced version of the 877A controller, plus it has more reliability and more efficient than its ancestor.

The traffic signal lights are connected to the ports of the microcontroller through a resistor. The XBee module is connected to the TX and RX terminals of the microcontroller through the RX and TX terminals of the module respectively. The strength of the signal is displayed in the LCD display through which the distance of the ambulance from the traffic signal can be calculated. The various parameters of the patient like heart beat rate and temperature are sent to the hospital from the ambulance through the GSM module. Through this data, the doctor can send feedbacks of the condition of the patient. These data are measured with the help of temperature sensor and heartbeat sensor.

IV HARDWARE IMPLEMENTATION

Hardware is the main working component of any paper. A hardware implementation means that the job is done using a physical device or electronic circuit as opposed to being done by a computer program. A hardware implementation often takes longer to create and that can make it more expensive. It is usually faster in operation and has the advantage that once built it cannot easily be tampered with or reprogrammed.

The main hardware components used in our paper are listed as follows:

- ❖ PIC16F1526 Microcontroller
- ❖ XBee Transmitter and Receiver with RSSI
- ❖ USB-Serial Interfacing Cable
- ❖ LED Lamps (Red, Yellow, Green)
- ❖ LCD Display (LM016)
- ❖ Temperature sensor (LM35)
- ❖ Heart beat sensor
- ❖ Defibrillator
- ❖ Other Miscellaneous components (Resistors, Capacitors, Wires, Diodes etc.)

A. Microcontroller Development Board



Fig. 5. Microcontroller Development Board

The figure 5 shows the Microcontroller development board. This board consists of various important in-built components. Some of these components are as follows:

- ❖ PIC Microcontroller
- ❖ Power Supply Circuit
- ❖ LCD Interface
- ❖ USART Communication Peripherals
- ❖ MAX232 Serial Communication IC
- ❖ Input/output ports of the Microcontroller

B. XBee Module

In our paper, the XBee module is fitted with RSSI to detect the presence of the ambulance under emergency condition. This module consists of a transmitter and a receiver. Both are the same modules, but once programmed, each is permanently fixed as a transmitter and other as receiver. The following figure 6 shows the XBee module fitted with RSSI which we have used in our paper.



Fig. 6. XBee Module

C. Traffic Lights using LEDs

In our paper, we have used LED lights as the traffic signal lights. As discussed earlier, the traffic signal consists of lights of three colors, namely red, yellow and green. Here in our paper, we have used two traffic posts, both for illustrating the changing of the traffic signal when the ambulance arrives.



Fig. 7. Traffic Lights using LEDs

D. Fabrication of Hardware

The above mentioned components have been assembled and formed into a single unit. The transmitter side is fitted to the ambulance, which will send the heartbeat rate and temperature of the patient to the hospital. The receiver is fitted to the traffic signal, which will change the traffic lights if the ambulance is detected within the range of the RSSI. The following images show the hardware fabrication of our paper.



Fig. 8. Receiver Hardware

In the figure 8, the receiver hardware is shown. Here the inputs to the traffic signal are taken from the B port of the microcontroller. The pins RB0-RB5 are used as we have used two traffic signal posts, with 3 pins for each port. The XBee module fitted with RSSI is connected to the RX and TX pins of the microcontroller. This entire setup is fitted to the traffic signal.

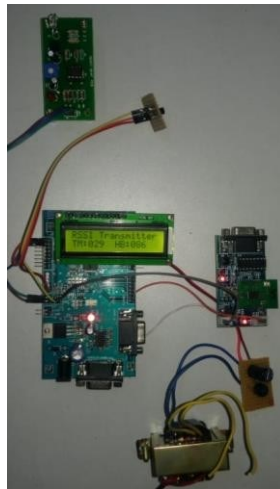

Fig. 9. Transmitter Hardware

In the figure 9, the transmitter hardware is shown. Here the temperature and heartbeat sensors are connected to the RA4 and RA5 pins of the microcontroller. The temperature sensor used is LM35 and the heartbeat sensor used is a PCB with the heartbeat sensor circuit embedded within it. A measurement was made and the temperature was sensed to be 29°C and the heartbeat rate was found to be 86bpm. Just like the receiver, the XBee module is connected to the RX and TX pins of the microcontroller. This entire setup is fitted inside the ambulance.

V SOFTWARE IMPLEMENTATION

The software is one of the most important parts of any paper. We have used microcontrollers and XBee modules in our paper. So it's natural that programming codes are used in these components.

The following softwares have been used in our paper:

- ❖ EasyEDA (For designing the circuit)
- ❖ MPLAB IDE v8.92 (For programming the microcontroller)
- ❖ PICKit 3 v3.10 (For burning the program into the microcontroller)
- ❖ PuTTY (For checking the communication of RSSI)

The following image shows the software implementation we have done.

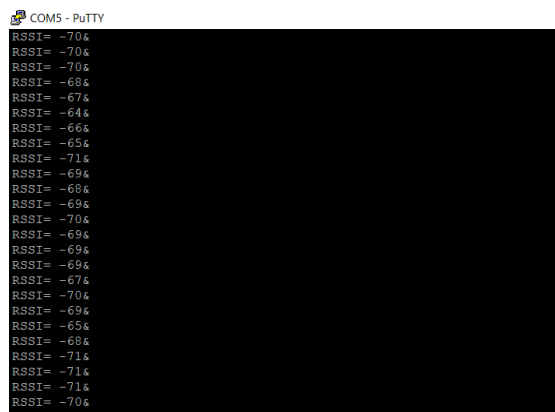

Fig. 10. PuTTY Software

In the figure 10, the values of the signal strength from the transmitter are being measured by the receiver. The software used is PuTTY. These values clearly say that the RSSI value reduces if the distance between the transmitter and receiver reduces. If the distance between the transmitter and receiver increases, then the value increases.

VI RESULT

From this proposed system, it can be seen that the traffic signal changes automatically to green when an ambulance is detected within the RSSI range. When the ambulance crosses the traffic signal, the regular flow of sequence is restored. If suppose the ambulance turns in a street before the traffic signal, then the XBee can detect that the ambulance is going out of range and so the traffic signal turns back to red or to whatever state it was.

VII CONCLUSION

From the analyses and simulations, it is estimated that the ambulance detection under emergency conditions in our proposed system is more efficient and reliable than the system stated in [9]. The system proposed in [9] is possible only through prototype, and cannot be brought under real-life implementation. The system proposed in [17] has a new technology of “Li-Fi” which makes use of communication through light, but it has a limitation that light cannot pass through opaque objects. So our proposed system is more efficient than the existing systems.

A. Merits

- ❖ The ambulance can pass through the traffic signal in the shortest possible time.
- ❖ The patient can be taken to the hospital without much delay.
- ❖ The XBee transmitter or receiver cannot be linked with any other module due to the programming.
- ❖ The range of the XBee can be extendable upto 1km.

B. Demerits

- ❖ If the road users are not well informed about the system, they might be stubborn to allow the ambulance to pass through. So the road users should be well-informed about the system and about the kind of emergencies occurring under such circumstances.
- ❖ If due to theft the ambulance doesn't start, then another ambulance has to be arranged, which increases complexity and cost.
- ❖ Connection of components in the controller board and the modules is a laborious task.

C. Future Scope

In our proposed system, the data of the patient is sent to the doctor in the hospital. This can be improved by including a video feature in which the doctor can see the patient through the video, and the doctor can easily analyze the patient's condition using the data and the video and can guide the nurse in the ambulance what to do.

REFERENCES

- [1] Abubakr S. Eltayeb, Halla O. Almubarak, Tahani Abdalla Attia “A GPS Based Traffic Light Pre-emption Control System for Emergency Vehicles”
- [2] Athavan. K, G. Balasubramanian, S. Jagadeeshwaran, N. Dinesh “Automatic ambulance rescue system”
- [3] Avishek Dan, Subir Halder, Sipra Das Bit “Localization with Enhanced Location Accuracy using RSSI in WSN”
- [4] Charmaine Toy, Kevin Leung, Luis Alvarez, and Roberto Horowitz “Emergency Vehicle Maneuvers and Control Laws for Automated Highway Systems”
- [5] David Bernstein & Ammar Y. Kanaan “Automatic vehicle identification: technologies and functionalities”
- [6] Faisal A. Al-Nasser, Hosam Rowaihy “Simulation of Dynamic Traffic Control System Based on Wireless Sensor Network”
- [7] Jais M.I, P. Ehkan, R.B. Ahmad, I. Ismail, T. Sabapathy, M. Jusoh, H.A. Rahim, M.F. Malek “Hardware Comparison Capturing Received Signal Strength Indication (RSSI) for Wireless Sensors Network (WSN)”

- [8] Jais M.I, T.Sabapathy, M.Jusoh, P. Ehkan, L.Murukesan, I.Ismail, R.B. Ahmad “Received Signal Strength Indication (RSSI) Code Assessment for Wireless Sensors Network (WSN) Deployed Raspberry-Pi”
- [9] Janani Saradha. B, G.Vijayshri, T.Subha “Intelligent Traffic Signal Control System For Ambulance Using RFID and CLOUD”
- [10]Jian Ming, Nailian Hu, XiangshanNiu, Yi Zhang “Study on the Personnel Localization Algorithm of the Underground Mine Based on RSSI Technology”
- [11]Kaibi Zhang, Yangchuan Zhang ,Subo Wan “Research of RSSI Indoor Ranging Algorithm Based on Gaussian - Kalman Linear Filtering”
- [12]Minchul Shin, Sung Ho Cho &Inwheel Joe “An Experimental Analysis of Effects of IEEE 802.11 Channels on RSSI-based Indoor Localization System with IEEE 802.15.4”
- [13]MirkoIvanić, Ivan Mezei “Distance Estimation Based on RSSI Improvements of Orientation Aware Nodes”
- [14]Naglaa El Agroudy1, George Georgiades, Niko Joram and Frank Ellinger “RSSI Overboard Localization System for Safe Evacuation of Large Passengers Ships”
- [15]Pitu B. Mirchandani and David E. Lucas “Integrated Transit Priority and Rail/Emergency Preemption in Real-Time Traffic Adaptive Signal Control”
- [16]Sajal Kumar Das “Modulation and transmitted data sequence independent carrier RSSI estimation”
- [17]Shanmughasundaram R, PrasannaVadanan S, VivekDharmarajan “Li-Fi Based Automatic Traffic Signal Control for Emergency Vehicles”
- [18]Shi Shuo , Sun Hao, GuXuemai& Jiang Yanjun “A Novel Rssi-Based Position Algorithm for Wireless Sensor Networks and Design of an Experimental System”
- [19]Sung-IL Hong, Chi-Ho Lin “An Expansion Cluster Routing Algorithm based on RSSI for An Efficient Data Transmission”
- [20]SuvankarBarai, Debajyoti Biswas, Buddhadeb Sau “Estimate Distance Measurement using Node MCU ESP8266 based on RSSI Technique”
- [21]Tandrima Chowdhury, Smriti Singh, Dr.S.MaflinShaby“A Rescue System of an Advanced Ambulance Using Prioritized Traffic Switching “

